



Technical Information

Installation of fabric expansion joints

RAL-GZ 719

TI-010

Rev. 1

page 1 of 6

1. General

- The installation shall be executed by safety-related instructed and experienced staff/personnel, required local- and project related safety arrangements have to be respected and coordinated with the site manager if applicable.
- The transport of the expansion joints to the installation location has to be carried out with reasonable care to avoid damages, the TI-008 has to be respected.
- The planning of the installation according to TI-009 needs to be finished
- The following steps for installation include the minimum standards for the installation process

Primarily respect the equipment manufacturers specific instructions

- Read this entire instruction prior starting the installation process and particularly refer to top "7. Warnings"

2. Internal Insulation (if applicable)

2.1. Manufactured pillow

- Insert insulation pillow according to manufacturers instruction, note marking "inside" and "outside" (refer to graph 2.1a)
- Locate the splice at the top side of the duct
- The splice areas shall be executed without any gap, if applicable sew splices together
- The peak of the pins which hold the insulation pillow shall not face towards the expansion joint (refer to graph 2.1a)

Graph 2.1a

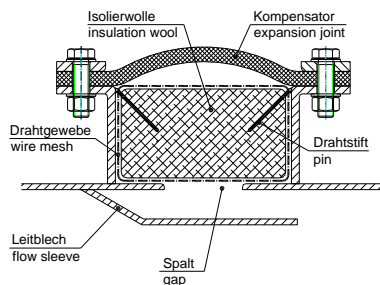

Graph 2.1b

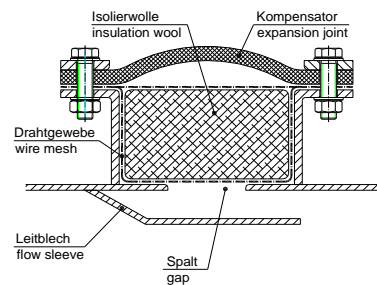

Edited by the Quality Committee of the Quality Association
for Fabric Expansion Joints



Technical Information

Installation of fabric expansion joints

RAL-GZ 719

TI-010

Rev. 1

page 2 of 6

2.2. Cut insulation mat

- Insert wire mesh to cover the open gap and if applicable fix the wire mesh.
- Cover the entire gap with insulation wool (refer to graph 2.2a)
- Locate splice preferably at the top side of the duct
- The splice areas shall be executed without any gap, if applicable sew splices together
- The stitched wire mesh of the insulation mat has to face the flow sleeve to avoid damages (refer to graph 2.2a or graph 2.2b)
- The peak of the pins which hold the insulation pillow shall not face towards the expansion joint (refer to graph 2.2a)

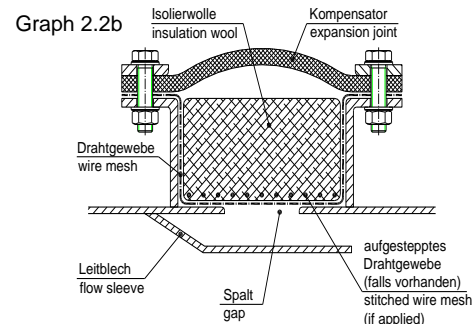
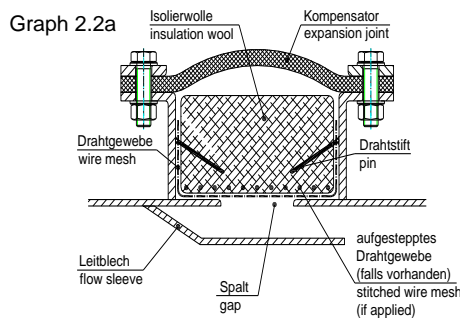

3. Expansion joint orientation and fixation

- Spread out the expansion joint, note marking "inside" and "outside", align and if applicable pre-compress expansion joint.
- Possibly respect allocation of different interface dimensions.
- For expansion joints with rectangular cross sections locate the corners respectively the corner radius.
- Note the location of the field splice at areas with proper access, refer to graph 3.a and graph 3.b (for horizontal orientated ducts possibly on the top side).
- Fix the expansion joint temporarily with suitable appliances e.g. c-clamps. The splicing area of endless joints shall not be fixed.

Edited by the Quality Committee of the Quality Association
for Fabric Expansion Joints



Technical Information

Installation of fabric expansion joints

RAL-GZ 719

TI-010

Rev. 1

page 3 of 6

Graph 3.a

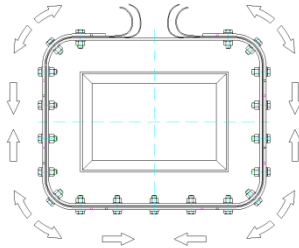

For open ended expansion joints with rectangular cross sections start from the corners. Spread out material equally between the fasteners

Graph 3.b

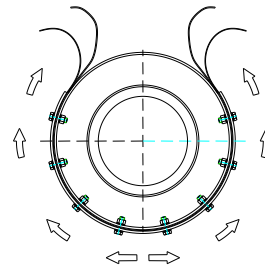

For open ended expansion joints with circular cross sections start from the opposite side of the splice and work in both directions towards the splice

4. Splicing

Each layer will be spliced separately. The splices of the single layers shall be staggered.

- According to their nature weld, glue or sew and seal coated fabrics together.
- Overlap and sew uncoated fabrics
- Preferably weld or glue the gas barrier (sealing layer), or fold it if applicable
- Overlap felt and non-woven materials according to their type and thickness, avoid material accumulation by executing cascaded overlaps
- Primarily respect the equipment manufacturers specific instructions for processing the materials

5. Punching the expansion joint for bolted connections

- The width of the contact surface of the expansion joint should be at least the same width as the backup flange.
- Punching with a drilling machine:
 - utilize the clamp bar segments as hole pattern
 - press expansion joint, back up flange segment and flange together with c-clamps
 - carefully drill fabric with moderate force
- Punching with a hollow punch:

**Edited by the Quality Committee of the Quality Association
for Fabric Expansion Joints**



Technical Information

Installation of fabric expansion joints

RAL-GZ 719

TI-010

Rev. 1

page 4 of 6

- mark bolt holes according to the existing hole pattern
- punch holes with a hollow punch on a suitable support (thick wooden board)

6. Fixation of the expansion joint

6.1. Bolted connection

- Place the backup flange/-bar as shown in graph 6.1 and adjust them according to the bolt hole pattern, preferably use shims

to 6.1. Bolted Connection

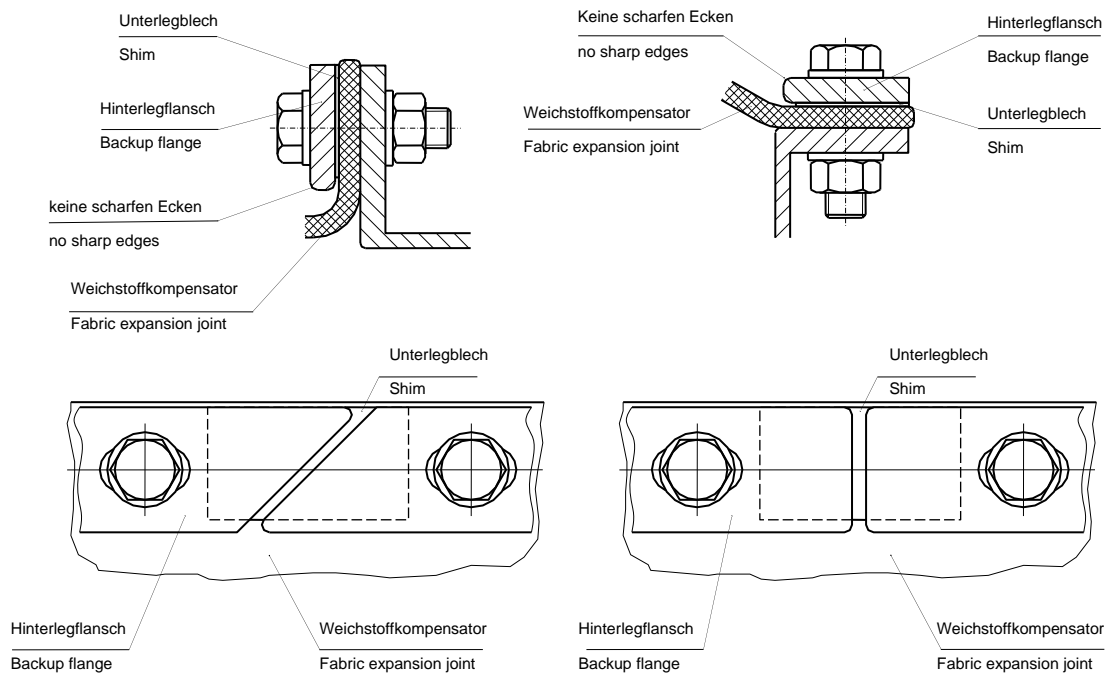

- Note assembly of the fasteners (location of the bolt head, washer, disc spring and so on)
- Insert the bolting and tighten it
- Fasten all bolts with the manufacturers recommended bolt torque in two or three rounds; refer to TI-007

**Edited by the Quality Committee of the Quality Association
for Fabric Expansion Joints**



Technical Information

Installation of fabric expansion joints

RAL-GZ 719

TI-010

Rev. 1

page 5 of 6

- The backup flange/-bar segments must not be in touch after several retightening; note setting of the expansion joint material

6.2. Fixation with clamp bands, straps and external clamps

- Position clamp bar/ back-up bar segments and adjust them, preferably use shims

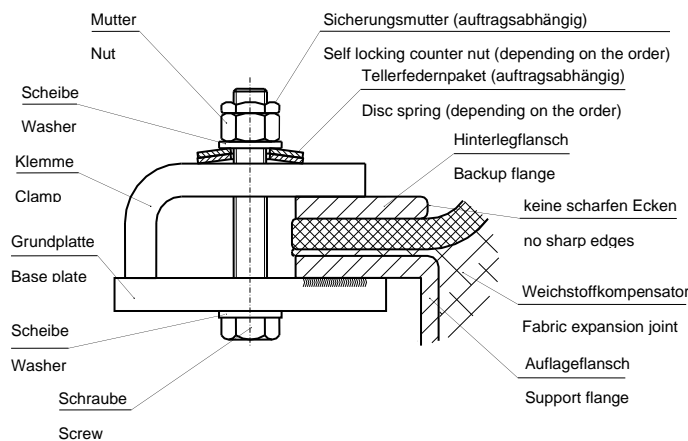

- Note assembly of the fasteners (location of the bolt head, washer, disc spring and so on)
- Insert the bolting and tighten it
- Fasten all bolts with the manufacturers recommended bolt torque in two or three rounds; (NOTE: the recommended bolt load of TI-007 is not valid for external clamps!)
- The clamp bar/back-up bar segments must not be in touch after the entire retightening; note setting of the expansion joint material

6.3. Clamp bands, straps and external clamps

- Position and align clamp bands, straps and external clamps
- Fasten all bolts on circumference in two or three rounds; (NOTE: the recommended bolt load of TI-007 is not valid for clamp bands, straps and external clamps!)
- The segments of the clamp bands, straps and external clamps must not be in touch after the entire retightening, note setting of the expansion joint material

**Edited by the Quality Committee of the Quality Association
for Fabric Expansion Joints**



Technical Information

Installation of fabric expansion joints

RAL-GZ 719

TI-010

Rev. 1

page 6 of 6

7. Warnings

The installation instruction may not describe all single steps precisely. To grant proper function it is strongly recommended to use preferably the manufacturer's installation materials.

The manufacturer's supervisor should be ordered for the installation work, specifically for the joining of the splice.

Attention: There is a high risk of danger in case of installations made by others (and not the manufacturer)!

**Edited by the Quality Committee of the Quality Association
for Fabric Expansion Joints**